

# 2019 Product Merchandising Brochure

**THERMA TRU**<sup>®</sup>  
DOORS



SHOWROOM | TRADE SHOWS | VISUALIZATION | LITERATURE | ADVERTISING

## Tools for Success.

DISPLAYS | SIGNAGE | SAMPLES | TRAINING | WEARABLES | HANDOUTS

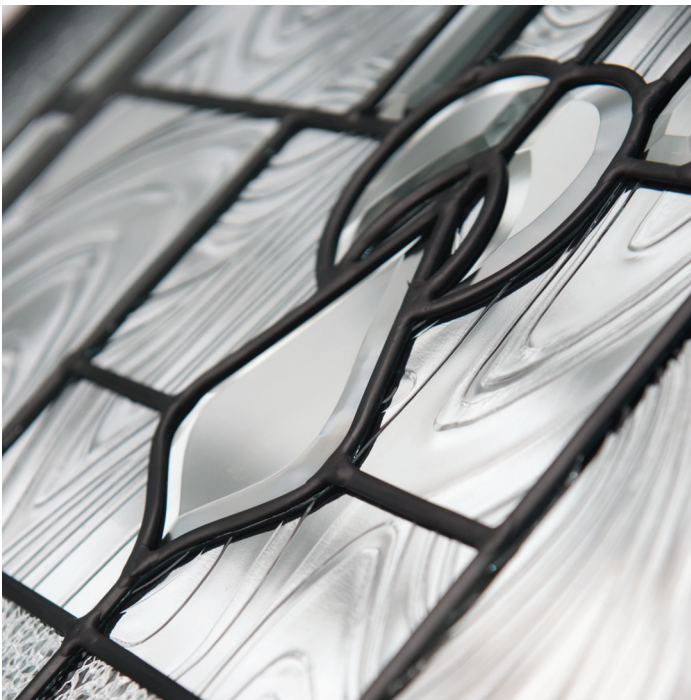

# Table of Contents

<b>Glass Displays</b> .....	4-5
<b>Door Displays</b> .....	5-9
<b>Display Door Signage</b> .....	9-10
<b>Showroom Signage</b> .....	11-13
<b>Product Samples</b> .....	14-19
<b>Literature</b> .....	20-22
<b>Training Aids &amp; Documents</b> .....	22
<b>Custom Marketing Program</b> .....	23
<b>Sell Sheet &amp; Door Signage Templates</b> .....	24
<b>Technical Documents</b> .....	24
<b>Company Store</b> .....	25
<b>Digital Tools</b> .....	26-27

Please visit our **Digital Vault** for a digital copy of this brochure.

**Distributors:** Please contact your dedicated Customer Account Representative to order the items shown in this brochure.

**Dealers:** If you are interested in any of the items shown in this brochure, please contact a Therma-Tru distributor in your area to place an order.

## The support you need for showroom success.

A solid partnership is all about support. Let us help you design your showroom and equip your staff to sell the value of Therma-Tru® doors.

## What's **NEW** in the showroom.

**Classic-Craft. American Style Collection™ Shaker-Style Door Labels | Page 10**

**Classic-Craft. American Style Collection™ Shaker-Style Door Section | Page 15**

**Privacy & Textured Glass Sample Case | Page 16**

**PrismaGuard™ Paint 4" x 4" Samples with Case | Page 18**

**PrismaGuard™ Stain & Paint Showroom Display Door | Page 18**

**Coastal System Storyboard | Page 19**

**Elevate 2019 Brochure | Page 21**

Display Terms: Pricing on any items listed in this brochure are subject to change without notice. Refer to your Customer Account Representative for lead times on displays. Freight is an additional cost and varies dependent on order and ship-to location. Displays must be shipped with full trucks direct to distributor.

# Tools for showroom success: See it. Feel it. Sell it.

Digital tools and devices are playing an increasingly prominent role in a customer's purchase decision. Today's consumers do their research – they are equipped with extensive product information before they ever step foot in a showroom.

However, they still appreciate the opportunity to see and feel the product in person. Many customers visit only one or two showrooms before making a final decision. Some prefer to take a brochure or flyer home so they can review their options at their own pace.

Consider the showroom environment you want to create. What impression does your showroom make on your customers? What tools would best help your customers experience the Therma-Tru® difference?

\*Source: Therma-Tru Shopper Journey Study, 2016; n = 751



Let your customers see and feel the difference.



## Interactive Glass Display (IGD)

**Interactive Glass Display**

Finished in Barley stain.

For support questions or issues, contact the IGD support team at 1-877-3TV-DOOR (388-3667) or tvdoor@thermatru.com.

- 50" commercial grade LED television.
- Finished Classic-Craft. Mahogany Collection™ door.
- Pre-programmed tablet to view glass designs, coming options, privacy ratings, glass shapes and available door collections.
- Current glass can be shown and preferred glass designs can be shared via email (when connected to Wi-Fi).\*\*
- Mount to a wall with included hardware or choose the optional free-standing kit (see right).
- Header and side panel graphic included.
- Therma-Tru's Service and Support Plan covers replacement parts (tablets, TVs and other hardware), that stop working under normal operating conditions, for three years from the original ship date of the display.

4'0"w x 8'3"h x 2'8"d

MADINTERGLASSDISPLAY18PG

Net Price Each\*: \$3,050.00

**Free-Standing Kit (Optional)**

Turn your new Interactive Glass Display into a free-standing showstopper on the showroom floor. Includes a black back panel applied by brackets to hide any cords and a set of durable display feet.

4'0"w x 8'3"h x 2'8"d

MADINTERGLASSFREESTAND

Net Price Each\*: \$300.00

\*Pricing subject to change without notice.

\*\*Data charges may apply. The customer is responsible for any charges on their data plan.

Note: Artist's renderings shown for illustration purposes only.

# Glass Images for Your Showroom TV

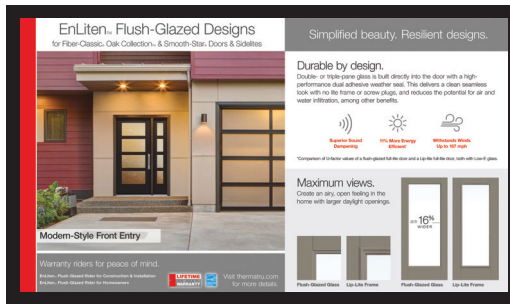
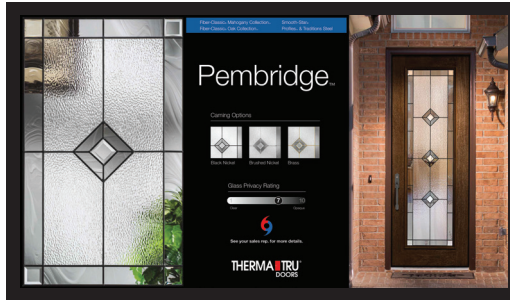

### Updated USB Flash Drive Only

USB flash drive featuring vertical and horizontal images of Therma-Tru® glass families and product messaging on continuous loop.

MADUSB19

Net Price Each\*: \$15.00

## DOOR DISPLAYS

# Single Operating Door Display

**Doors not included.**

Use this display structure to showcase a Therma-Tru door with your finish, trim and hardware options. Removable caster wheels can be screwed into the base to help transport the display to shows and events.

Includes:

- Display structure.
- Header sign.
- Side panel graphic.
- Levelers.
- Caster wheels.

Note: Fits doors that are 3'0" x 6'8" or smaller.

4'0"w x 8'3"h x 2'8"d

MADSNGOPDR15

Net Price Each\*: \$900.00



# 51

**PERCENT OF SHOPPERS** look at signage and displays when visiting a showroom.\*\*\*

The signage is important to the shopper to gather quick details about the product they're looking at.

\*\*\*Therma-Tru Shopper Journey Study, 2016; n = 751

# Expandable Pullout Door Display Unit

The display unit can be configured to fit your space: free-standing, against or recessed into a wall, or side-by-side / back-to-back with another unit.



Note: Shown with additional door mounting hardware kits.

## 8'0" Pullout Door Display Unit

**Doors and signage not included.**

Standard unit holds four 8'0" display doors and can expand to hold up to 10 8'0" display doors. Unit can also accommodate 6'8" doors by ordering a spacer frame (not included). Four door pull handles included.

MAD8TALLPULL18

Net Price Each\*: \$1,400.00

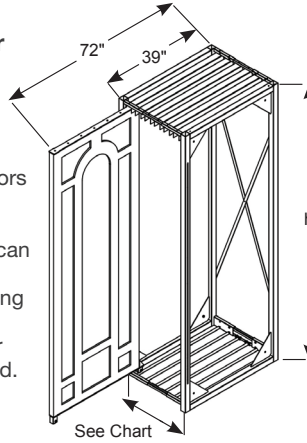

# of Doors	Unit Width
4	20"
5	24"
6	28"
8	36"
9	40"
10	44"

6'8" Unit: 7'4"h

8'0" Unit: 8'6-1/2"h



Note: Shown with optional graphics and side panel.

## 6'8" Pullout Door Display Unit

**Doors and signage not included.**

Standard unit holds four 6'8" display doors and can expand to hold up to 10 6'8" display doors. Four door pull handles included.

MAD68TALLPULL18

Net Price Each\*: \$1,350.00

## Optional Add-On Items

### Door Mounting Hardware Kit

Allows one additional 8'0" or 6'8" door to be installed in pullout door display.

MAD1DOORADDERPULL15

Net Price Each\*: \$145.00

### Spacer Frame System 1

For 6'8" door to fit 8'0" door display unit.

MADSPACERPULL15

Net Price Each\*: \$110.00

### Side & Back Panels

Black panel (laminated particle board) to fit flush within metal frame, secured with provided hardware in pre-drilled display structure.

#### Side Panel (1 panel) 2

■ 8'0" Door Display Unit: MAD8TALLSIDEPULL15

■ 6'8" Door Display Unit: MAD68TALLSIDEPULL15

#### Back Panel (fits 10 door units only)

■ 8'0" Door Display Unit: MAD8TALLBACKPULL15

■ 6'8" Door Display Unit: MAD68TALLBACKPULL15

Net Price Each\*: \$110.00

### Door Pull Handles 3

Purchase additional handles individually for existing units or when you choose to expand beyond the standard four-door configuration.

MADHANDLEPULL18

Net Price Each\*: \$22.50

Select the pieces and parts you need to make it your own. For ordering information, or to obtain the display configurator tool, contact your Customer Account Representative.

\*Pricing subject to change without notice.

Note: Artist's renderings shown for illustration purposes only.

## Pivot Wing Display Unit

**Doors and signage not included.**

Let customers easily browse your selection of Therma-Tru display doors while saving floor space in the showroom. The Pivot Wing Display Unit fits flush against the wall, offering a great way to organize more display doors. The doors fan open for customers to view all the options.

- Adjusts to show 6'8", 7'0" or 8'0" display doors for a total height of 102-1/2".
- Display unit mounts to wall with supplied hardware.
- Door bumper guard mounts to top of display doors.
- Notched to clear standard baseboards.
- Display unit holds a maximum of eight doors or four per side.
- If you choose to show handlesets, it is recommended they be installed only on the front two display doors to prevent damage to the other units.

90"w x 86-1/2"h x 14-1/2"d  
MADPWD17  
Net Price Each\*: \$700.00



## Swing Door Unit

Showcase the beauty of Therma-Tru doors with a swing display that can easily be customized for showroom placement. Standard unit holds four display doors and can be expanded to hold eight. Holds 6'8" and 8'0" doors.

**Swing Door Unit**  
**Doors not included.**

Each door can swing up to 160 degrees for a wide viewing angle.  
6'6"w x 7'10"h x 4'6"d  
MADGSWU15  
Net Price Each\*: \$2,500.00

**Expansion Kit**  
**Doors not included.**

Optional hardware kit allows the unit to hold up to eight display doors (four on each side or eight on one side).  
6'6"w x 7'10"h x 7'0"d  
MADGHKSU10  
Net Price Each\*: \$400.00

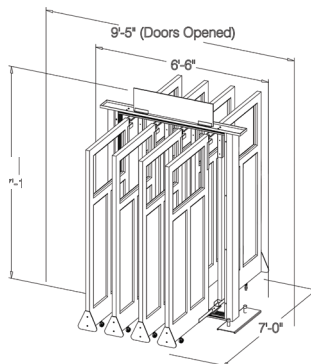
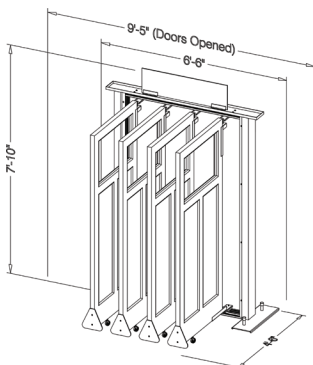

Note: Shown with expansion kit, eight doors on one side.

## Display Door Stands

### Revolver Slab Display

*Doors not included.*

This set includes:

- 1 One header sign.
- 2 Two revolver face plate graphics.
- 3 One revolver stand.

MADRS95 – 6'8" door

Net Price Each\*: \$50.00

MADRS897 – 8'0" door

Net Price Each\*: \$60.00



### Display Feet (Set of 2)

Maximize your space with this solution to display free-standing Therma-Tru doors in the showroom or at trade shows.

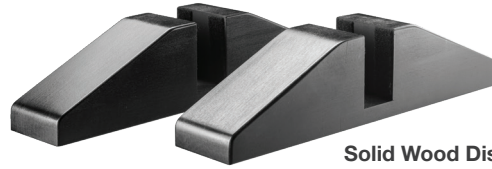

#### Solid Wood Display Feet

3-1/2" w x 4-1/2" h x 18" d

MADSWDISPFEEET

Net Price Each\*: \$75.00



#### MDF Composite Display Feet

3-1/2" w x 4-1/2" h x 18" d

MADCOMPDISPFEEET

Net Price Each\*: \$40.00

## Three-Sided Display Stand

*Doors not included.*

Let customers see and experience your Therma-Tru door offering up close, with a door stand that conveniently displays multiple entry doors.

Showcase either three 6'8" or 8'0" display doors using three corner connectors that attach to top and bottom of doors.

Three header signs included (see page 10 for options).

47-1/2" w x 7'10" h x 46-3/4" d

MADDRSTAND

Net Price Each\*: \$40.00

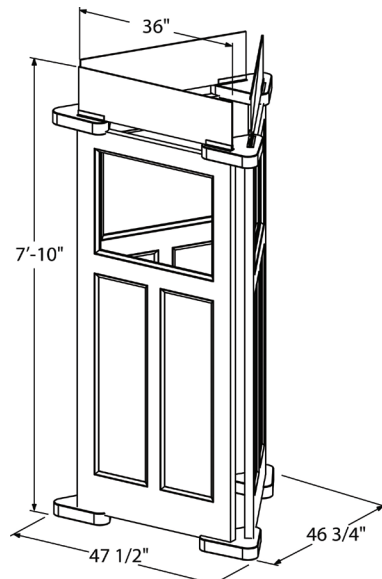

\*Pricing subject to change without notice.

Note: Artist's renderings shown for illustration purposes only.



# Premium Triangular Display

**Doors not included.**

**1** Three doors on each side.

47-1/2" w x 7'10" h x 46-3/4" d

D3035196-X30E

Net Price Each\*: \$225.00

**2** **Additional display option:** Replace one display door with a panel of two sidelites and a center graphic.

47-1/2" w x 7'10" h x 46-3/4" d

D3035196-X31E

Net Price Each\*: \$100.00

The Premium Triangular Display can be customized to best represent your inventory. Showcase either three display doors or two doors and a panel of two sidelites with center graphic installed in a durable metal structure. Display fits 6'8" or 8'0" doors.

Display unit includes a 9-1/8" w x 9-5/8" h x 2-5/8" d literature holder, perfect for an 8-1/2" w x 11" h brochure.

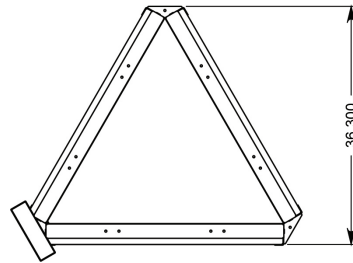

## DISPLAY DOOR SIGNAGE

### Door Pulls

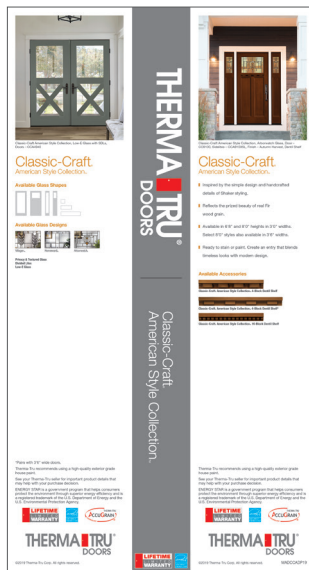

All display doors ship with a plexicover and appropriate door pull. Reference the list below to order replacements.

**Ask about custom imprint options when you order.**

- Updated** Classic-Craft® American Style Collection™ – MADCCADP19
- Updated** Classic-Craft® Mahogany Collection™ – MADCCMDP19
- Updated** Classic-Craft® Rustic Collection™ – MADCCRDP19
- Updated** Classic-Craft® Oak Collection™ – MADCCODP19
- Updated** Classic-Craft® Canvas Collection™ – MADCCVDP19
- Updated** Fiber-Classic® Mahogany Collection™ – MADFCMDP19
- Updated** Fiber-Classic® Oak Collection™ – MADFCODP19
- Updated** Smooth-Star® – MADSSDP19
- Updated** Profiles™ – MADPSHDDP19
- NEW** Traditions – MADTSDP19
- Updated** Pulse® – MADPLSDP19
- Updated** Internal Blinds – MADIBDP19
- Updated** EnLiten™ Flush-Glazed Designs – MADFGDP19
- Updated** Impact-Rated – MADIMPDP19

Net Price Each\*: \$1.50

Graphic Plexicover (screws not included) – MAPLEXU

9-1/4" w x 17" h

Net Price Each\*: \$6.00



**Updated** PrismaGuard™ door pulls are available for custom development and can be tailored to your needs. Talk to your Therma-Tru sales representative for more information.

# Header Signs

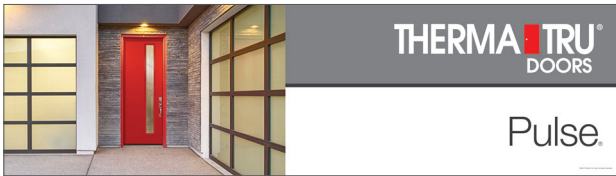

36" w x 10" h

**Updated** Classic-Craft, Premium Entryways – MADHEADCC19

**Updated** Fiber-Classic, Collections – MADHEADFC19

**Updated** Smooth-Star. – MADHEADSS19

**Updated** Pulse. – MADHEADPLS19

Therma-Tru® Brand – MADGHDR17

Net Price Each\*: \$20.00

Header Sign Clips (sold separately) – MADGATTACHMENT

Net Price (Set of 2)\*: \$2.00

# Therma-Tru® Display Labels



## Lifetime Limited Warranty Label

Removable display label.

3" w x 3" h

MAWLBL14

Net Price Each\*: \$0.45

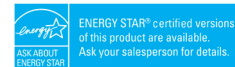

## ENERGY STAR® Label

Removable display label.

3-1/2" w x 1" h

MADENERGYSTAR

Net Price Each\*: \$0.40

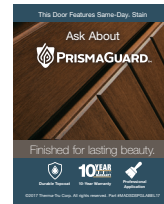

## PrismaGuard™ Label

Removable label for display doors stained with Same-Day, Stain that can now be ordered in PrismaGuard.

4-3/4" w x 3-3/4" h

MADSDSPGLABEL17

Net Price Each\*: \$0.40



## NEW Classic-Craft, American Style Collection™ Shaker-Style Door Label

Removable display label.

4" w x 5" h

MADCCALBL19

Net Price Each\*: \$0.40



## DoorWays™ App Label

Removable display label.

3-3/4" w x 3-3/4" h

MADWYAPLBL17

Net Price Each\*: \$0.50

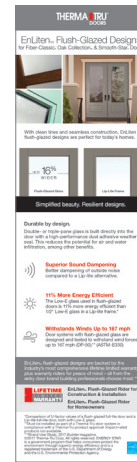

## EnLiten™ Flush-Glazed Designs Label

Removable display label.

3-1/2" w x 12-1/4" h

MADFGLBL18

Net Price Each\*: \$0.40

# Consumers Digest Materials

Promote the fact that *Consumers Digest* has designated the Therma-Tru Classic-Craft and Fiber-Classic lines of entry doors as Best Buy selections.

Visit [thermatru.com/trade-professionals/consumersdigest](http://thermatru.com/trade-professionals/consumersdigest) to order Therma-Tru *Consumers Digest* promotional materials for your showroom free of charge.

Available:

- **Updated** Label
  - Classic-Craft Only (shown right)
  - Fiber-Classic Only
- **Updated** Flyer
- Guidelines



# Vinyl Banners





**THERMA-TRU<sup>®</sup>**  
DOORS

Fiberglass Entry & Patio Door Systems

Home begins  
at the door.

**Updated Therma-Tru.  
13 oz. Vinyl Banner**

Banner with six grommets for indoor / outdoor use.

6'0"w x 3'0"h

MALTTB

Net Price Each\*: \$55.00





**THERMA-TRU<sup>®</sup>**  
DOORS

Fiberglass Entry & Patio Door Systems

Home begins at the door.

Imprint Area  
Remove Before Printing

**Updated Therma-Tru.  
13 oz. Vinyl Banner (Customizable)**

Banner with six grommets for indoor / outdoor use. Space provided for your four-color company logo and / or copy.

6'0"w x 3'0"h

MALTTCB

Net Price Each\*: \$55.00

## Showroom Window Cling



**Authorized Therma-Tru. Dealer Window Cling – Double-Sided**

24"w x 10"h

MAFTTADD

Net Price Each\*: No Charge



\*\*Therma-Tru Shopper Journey Study, 2016; n = 751

# Pull-Up Banners

Perfect for trade shows, these portable banners are available in a variety of topics to enhance your sales pitch. Display stands are included. Choose from: National Home Valuation Study, EnLiten™ Flush-Glazed Designs, PrismaGuard™, Fiberglass vs. Wood or Architectural Home Styles Guide.

33-1/2" w x 78-1/2" h

Net Price Each\*: \$80.00

**1**

Now that's a **smart investment.**

**THERMA TRU DOORS**

A stylish new Therma-Tru entry door can **increase** a home's perceived **value** by an average of **4.2%** or **\$18,750.**

For more information and inspiration visit [www.thermatru.com/curbappeal](http://www.thermatru.com/curbappeal).

**2**

EnLiten Flush-Glazed Designs  
for Fiber-Classic Oak Collection & Smooth-Star Doors & Sidelites

**THERMA TRU DOORS**

Simplified beauty. Resilient designs.

Seamless construction eliminates the need for a lite frame or screw plugs.

**16% WIDER**

Flush-Glazed Glass | Lip-Lite Frame

**Durable by design.**  
Double- or triple-pane glass is built directly into the door with a high-performance dual adhesive weather seal. This reduces the potential for air and water infiltration, among other benefits.

**Superior Sound Dampening**  
Better dampening of outside noise compared to a Lip-Lite alternative.

**11% More Energy Efficient**  
The Low-E glass used in flush-glazed doors is 11% more energy efficient than 1/2" Low-E glass in a Lip-Lite frame.

**Withstands Winds Up to 167 mph**  
Door systems with flush-glazed glass are designed and tested to withstand wind forces up to 167 mph (DP-50) (ASTM-E330)

**LIFETIME WARRANTY**  
EnLiten™ Flush-Glazed Rider for Connections & Installation  
EnLiten™ Flush-Glazed Rider for Hardware

**3**

**THERMA TRU DOORS** | **PRISMA GUARD™**

Finish for lasting beauty.

**10 YEAR WARRANTY**

Inspired by nature.

**4**

**THERMA TRU DOORS**

The advantage is clear.

**THINK YOU WANT A WOOD DOOR?** | **THINK AGAIN.**

Wood Doors	Therma-Tru Fiberglass Doors
<ul style="list-style-type: none"> <li>• Demand regular upkeep.</li> <li>• Can easily scratch.</li> <li>• May split and crack.</li> <li>• Absorb moisture, and may rot and warp.</li> <li>• Refresh every 1-2 years.</li> </ul>	<ul style="list-style-type: none"> <li>• Require minimal maintenance.</li> <li>• Resist dents and scratches.</li> <li>• Won't split or crack.</li> <li>• Don't absorb moisture, and won't rot or warp.</li> <li>• Reapply topcoat every 3-5 years, or when glass fades.</li> </ul>

Wood or Fiberglass?  
You decide.

**5**

Find Your Match.  
ARCHITECTURAL HOME STYLES GUIDE

[homestyles.thermatru.com](http://homestyles.thermatru.com) | **THERMA TRU DOORS**

Browse Therma-Tru doors by home style, including options for the entire house.

Choose a door that brings out the best of your home's style.

- 1** National Home Valuation Study  
MADNHVSPUBANNER18
- 2** EnLiten™ Flush-Glazed Designs  
MADFGPUBANNER18
- 3** Updated PrismaGuard™  
MADFGPUBANNER19
- 4** Fiberglass vs. Wood  
MADFWPUBANNER18
- 5** Updated Architectural Home Styles Guide  
MADAHSPUBANNER19

\*Pricing subject to change without notice.

# Posters

Take advantage of wall space to showcase the beauty of Therma-Tru® products in your showroom. These vibrant images are printed on a durable styrene material that's sturdy enough to hang without a frame.

24" w x 36" h

Net Price Each\*: \$25.00



**Updated Classic-Craft.  
Premium Entryways**  
MADPOSTCC19



**Updated Fiber-Classic.  
Collections**  
MADPOSTFC19



**Updated Smooth-Star.**  
MADPOSTSS19



**Updated Pulse.**  
MADPOSTPLS19



**Updated Impact-Rated  
Products**  
MADPOSTIMPACT19

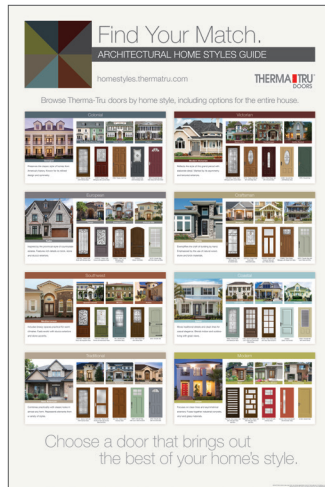

**Updated Architectural  
Home Styles Guide**  
MADPOSTAHS19



**A Complete Door System**  
MADPOSTETWT17



**Door Construction**  
MADPOSTDC17

# Countertop Displays

Product Samples



**Smooth-Star. Countertop**  
*Case not included.*

One side painted white and one side unfinished.  
13"w x 13-1/2"h  
MADA200S07  
Net Price Each\*: \$105.00



**Classic-Craft. Mahogany Countertop**  
*Case not included.*

One side painted tan and one side stained Barley.  
13"w x 13-1/2"h  
MAD0103CM18PG  
Net Price Each\*: \$160.00



**Classic-Craft. Mahogany & Smooth-Star. Countertop Case**

Messenger-style bag with shoulder strap and handle for ease of transporting samples.  
Carrying case only.  
17"w x 15"h x 8"d  
MACTRSTB12  
Net Price Each\*: \$50.00



**Lever-Style Multi-Point Locking System**  
*Case not included.*  
8"w x 34"h x 5"d  
MADMPLS  
Net Price Each\*: \$200.00



**Grip-Style Multi-Point Locking System**  
*Case not included.*  
8"w x 34"h x 5"d  
MADGSMPLS  
Net Price Each\*: \$315.00



**Multi-Point Locking System Case**

Carrying case only. Fits either Lever-Style or Grip-Style Multi-Point Locking System.  
10"w x 37"h x 10"d  
MADMPCS  
Net Price Each\*: \$125.00

# Door Cutaways

Door cutaways offer a great way to highlight specific high-quality construction attributes of Therma-Tru® doors, such as the sturdy lock stile and seamless flush-glazed look.



**Double-Sided  
Flush-Glazed Door  
Section with Clear Glass**

Finished in Raven stain.  
Door section with stained Fiber-Classic. Oak on one side and Smooth-Star® unfinished on the other side.  
14"w x 14"h  
MADFCOSSFGCL18PG-SDL  
Net Price Each\*: \$140.00



**Double-Sided  
Flush-Glazed Door  
Section with Privacy &  
Textured Glass**

Finished in Raven stain.  
Door section with stained Fiber-Classic. Oak on one side and Smooth-Star® unfinished on the other side.  
14"w x 14"h  
MADFCOSSFGXE18PG  
Net Price Each\*: \$160.00



**NEW Classic-Craft.  
American Style  
Collection™ Shaker-Style  
Door Section**

Door section finished in Wildflower Honey stain on one side and unfinished on the other.  
12"w x 12"h  
MADCCSHKR18  
Net Price Each\*: \$30.00



**Smooth-Star. Shaker-Style  
Door Section**

Door section painted white on one side and unfinished on the other.  
12"w x 12"h  
MADSSSHKR17  
Net Price Each\*: \$22.50



**Classic-Craft. Mahogany  
Door Section with  
Lock Stile**

Finished in Barley stain.  
12"w x 12"h  
MAPGMH18  
Net Price Each\*: \$30.00



**Impact-Rated Glass /  
Lip-Lite Frame Sample**

6"w x 8"h  
MADIG07  
Net Price Each\*: \$70.00



**Smooth-Star.  
Solid-Panel Impact-Rated  
Door Sample**

6"w x 6"h  
MADOG07  
Net Price Each\*: \$45.00

## Glass Samples



### Glass Case

Case has all field glass samples in 3" w x 3" h size.

8" w x 9-1/4" h

MASGC17

Net Price Each\*: \$190.00

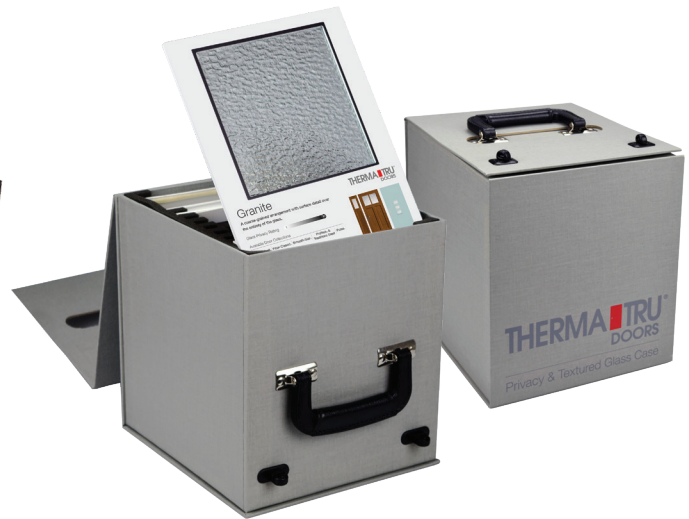

### NEW Privacy & Textured Glass Sample Case

Case contains five 8" x 10" display boards featuring 6" x 6" samples of our privacy and textured glass assortment. One 8" x 6" IG is also included.

9" w x 9-5/8" h x 10" d

MAPTGSC19

Net Price Each\*: \$250.00

## 12" x 12" Door Skin Samples

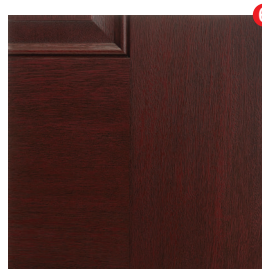
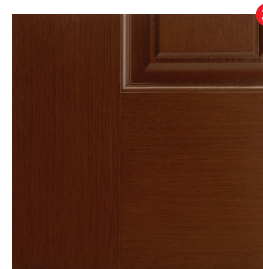
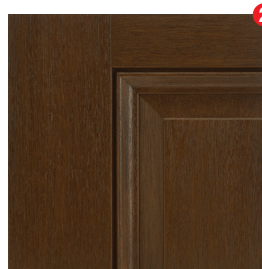
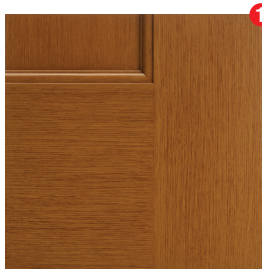

PG = PrismaGuard™ Stain

SW = Sherwin-Williams Paint

Door Collection	Stain / Paint	Part Number	Net Price Each*
1 Classic-Craft. American Style	PG – Wildflower Honey	MAPGOCCA18	\$20.00
2 Classic-Craft. Mahogany	PG – Barley	MAPGOCCM18	\$20.00
3 Classic-Craft. Rustic	PG – Autumn Harvest	MAPGOCCR18	\$20.00
4 Classic-Craft. Oak	PG – Driftwood	MAPGOCCO18	\$20.00
5 Classic-Craft. Canvas	SW 6106 Kilim Beige	MASDSOCCV17	\$20.00
6 Fiber-Classic. Mahogany	PG – Mulberry	MAPGOFM18	\$18.00
7 Fiber-Classic. Oak	PG – Raven	MAPGOF18	\$18.00
8 Smooth-Star.	SW 7042 Shoji White	MASDSOSS17	\$18.00

Note: Also available upon request as unfinished product.



## D2D (Door-to-Door) Travel Bag

Messenger-style bag with shoulder strap and handle. Includes:

- Decorative & Specialty Glass Collection Brochure.
- PrismaGuard™ finished 12" w x 12" h Classic-Craft. Mahogany door section.
- Finished 12" w x 12" h door skin samples in Classic-Craft. American Style, Classic-Craft. Rustic, Classic-Craft. Oak, Classic-Craft. Canvas, Fiber-Classic. Mahogany, Fiber-Classic. Oak and Smooth-Star.
- Extra compartment for other sales tools.

12" w x 13" h x 5" d

MADTTSTB17PG

Net Price Each\*: \$255.00

### Unfinished D2D Travel Bag

Same as above but with unfinished 12" w x 12" h door samples.

MADTTUFSTB11

Net Price Each\*: \$185.00



## Fiberglass Skin Sheets



### Fiberglass Skin Sheets

Standard package includes 14 unfinished sheets that can be cut to make 224 4" w x 4" h fiberglass skin samples.

Net Price Each\*: \$155.00 per box of 14 sheets

Description	Part Number
Classic-Craft. American Style	MASPSCCAUF-224
Classic-Craft. Mahogany	MASPSCCMUF-224
Classic-Craft. Rustic	MASPSCCRUF-224
Classic-Craft. Oak	MASPSCCOUF-224
Classic-Craft. Canvas	MASPSCCVUF-224
Fiber-Classic. Mahogany	MASPSFCMUF-224
Fiber-Classic. Oak	MASPSFCOUF-224
Smooth-Star.	MASPSSSUF-224

## Stain Samples



### Classic-Craft. Same-Day. Stain Fan Deck

Classic-Craft printed fan deck to compare seven Same-Day Stain colors among four different grain options.

MADCCFAN18

Net Price Each\*: \$40.00

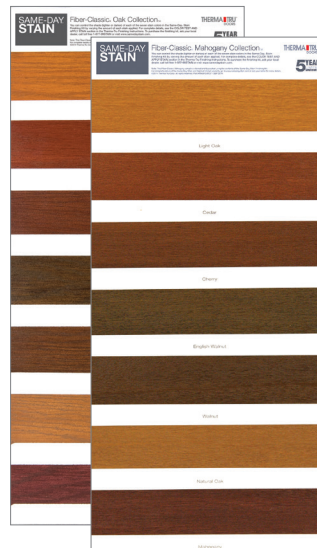

### Fiber-Classic. Mahogany Stain Chart

Chart featuring medium shades of all seven Same-Day Stain colors.

10-1/2" w x 24-1/2" h

MASFCM707

Net Price Each\*: \$37.50

### Fiber-Classic. Oak Stain Chart

Chart featuring medium shades of all seven Same-Day Stain colors.

10-1/2" w x 24-1/2" h

MASFC707

Net Price Each\*: \$37.50

## Stain Samples *Continued*

### PrismaGuard™ Stain Fan Deck

Classic-Craft™ and Fiber-Classic™ printed fan deck to compare nine PrismaGuard stain colors within each of the six grains.

MADPGSTAINFAN17

Net Price Each\*: \$70.00



### PrismaGuard™ Stain 4" x 4" Samples with Case

These portable cases are ideal for the in-home sales representative, allowing customers to browse stain colors on physical product samples. Each case shows nine PrismaGuard stain colors by collection. Extra sleeves are included for displaying additional colors. Embossed logo on the front.

A case specific to each grained collection:  
 MAPGCCA4X4CASE  
 MAPGCCM4X4CASE  
 MAPGCCR4X4CASE  
 MAPGCCO4X4CASE  
 MAPGFCM4X4CASE  
 MAPGFCO4X4CASE

Net Price Each\*: \$50.00



### NEW PrismaGuard™ Paint 4" x 4" Samples with Case

Same as above, but with eight PrismaGuard paint colors on Classic-Craft™ Canvas Collection™ skin chips.

MAPGCCV4X4CASE

Net Price Each\*: \$50.00

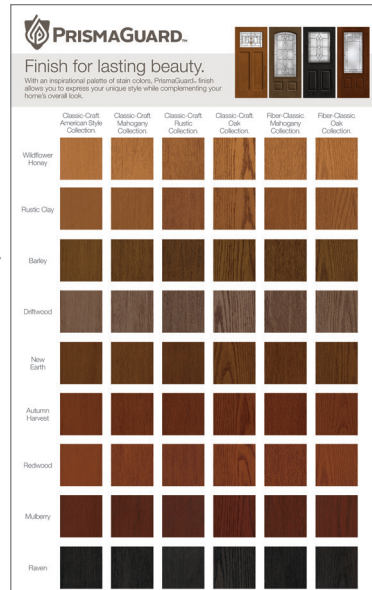

Front



Back

### PrismaGuard™ Stain Showroom Display Door

Experience the premium look and feel of PrismaGuard stain. This door, with printed graphics, displays 4" w x 4" h stained samples showing nine PrismaGuard stain colors in each of the six grains.

MADPGSHOWSTAINDOOR

Net Price Each\*: \$440.00

### NEW PrismaGuard™ Stain & Paint Showroom Display Door

Same as above, but with the addition of eight PrismaGuard paint colors shown on Classic-Craft Canvas Collection samples.

MADPGSHOWSTPTDOOR

Net Price Each\*: \$440.00

## Component Samples



### Grilles Between Glass (GBGs) Sample Chain

Represent the grille options in coordination with pre-finished color options and door availability.

MADGBGS14

Net Price Each\*: \$22.50



### Simulated Divided Lites (SDLs) Sample Chain

Represent the divided lite options in coordination with stain color options and door availability.

MADSDLSPG18

Net Price Each\*: \$22.50



### Security Strike Plate Comparison Sample

7" w x 4" h clear acrylic.

MADSSPC10

Net Price Each\*: \$35.00



### Hinge Board

Handheld board that includes eight mounted half hinges to represent hardware finish options: Polished Chrome, Stainless Steel, Brushed Nickel, Zinc Dichromate, Black Nickel, Bright Brass, Oil-Rubbed Bronze and Antique Brass.

11-3/4" w x 23-3/4" h

MADHSB18

Net Price Each\*: \$75.00

# Component Samples *Continued*



## Tru-Defense. Door System Components Board

Handheld board includes actual components:

- Inswing composite sill.
- Dual-bulb / dual-fin bottom sweep.
- Rain deflector.
- Medium- and long-reach side weatherstrip.
- Outswing composite sill.
- Classic-Craft® lock and hinge side corner seal pads.
- Fiber-Classic® / Smooth-Star® corner seal pads.
- Rain guard.
- Handleset.

24" w x 21" h

MADTDB17

Net Price Each\*: \$275.00

## System Storyboards



There's a story behind every door. Show homeowners the value of a Therma-Tru® door system. The System Storyboard makes it easy to demonstrate features and benefits with product samples and visual aids.

9-1/2" w x 20-1/2" h x 5-1/2" d

MADSTRYBD16

Net Price Each\*: \$215.00

### NEW Coastal System Storyboard

The Coastal System Storyboard allows you to show homeowners the value and benefits of a Therma-Tru door system, featuring components that meet building codes in coastal regions.

9-1/2" w x 20-1/2" h x 5-1/2" d

MADCSTLSTRYBD19

Net Price Each\*: \$215.00

Available to order April 2019.

## Literature

In our literature you can find all the details, features and benefits for all door, sidelite and transom options and accessories. And your customers can find inspiration to enhance their homes with Therma-Tru® doors.



### Updated 2019 Full-Line Catalog The Building Professionals' Entry & Patio Door Directory

Created specifically for trade professionals, this directory serves as a complete and easy-to-use guide with all the information needed to help specify and sell Therma-Tru products.

MAFL2019

Net Price Each\*: \$1.65



### Updated Pulse® Brochure

Designed to inspire trade professionals to make a bold statement with a contemporary studio of door styles and glass designs that transform the entrance into modern art.

MAFPULSEB19

Net Price Each\*: \$0.30



### Updated Classic-Craft® Premium Entryways Brochure

Let your customers experience the difference of a Classic-Craft entryway with its inspired blend of precision engineering and architectural character.

MAFCCB19

Net Price Each\*: \$0.45

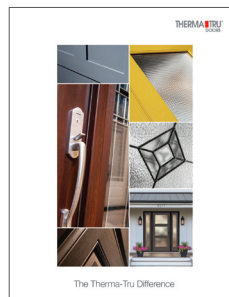

### Updated Therma-Tru® Door Systems Brochure

Explains the reasons why customers should choose Therma-Tru.

MAFWTT19

Net Price Each\*: \$0.50

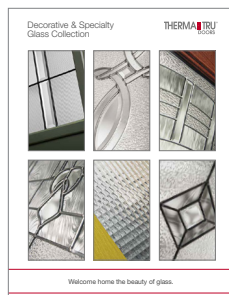

### Updated Decorative & Specialty Glass Collection Brochure

Show your customers how Therma-Tru glass makes entryways come to life with beauty and craftsmanship you can't find anywhere else.

MAFGLASS19

Net Price Each\*: \$0.90



### Updated New Product Flyers and 2-Minute Tru-Facts

Explains the features and benefits of Therma-Tru's new-for-2019 products: Satin Etch glass for Classic-Craft, flush-glazed internal blinds, new SDL configurations and more.

MAFTF19

Net Price Each\*: \$1.00

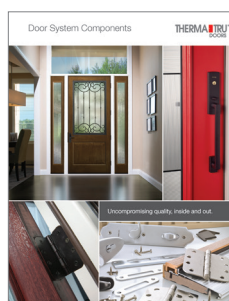

### Door System Components Brochure

Inspire confidence in a Therma-Tru door system made with genuine Therma-Tru components, engineered to work together and backed by our warranty.

MAFCOMP18

Net Price Each\*: \$0.50



### Updated Fiberglass & Wood Door Comparison Brochure

Educate your customers on the similarities and differences of fiberglass and wood – and offer them the best of both worlds with our Classic-Craft premium entryways.

MAFCOMPARISON19

Net Price Each\*: \$0.45



### Curb Appeal Brochure

Get inspired and find out how a new Therma-Tru entry door can increase perceived home value.

MAFCAB16

Net Price Each\*: \$0.25



### Updated Architectural Home Styles Guide

Get inspired to choose Therma-Tru entry doors by design with our guide to popular home styles.

MAFAHSG19

Net Price Each\*: \$0.65



**Updated 3'6" Entry Door Solutions Brochure**

Give an overview of Therma-Tru's 3'6" wide entry door options perfect for homes with grand entrances.

MAFTSEDS19

Net Price Each\*: \$0.35



**Updated Craftsman Doors & Sidelites Brochure**

Convey Therma-Tru's assortment of Craftsman-lite doors and sidelites for a touch of Craftsman appeal.

MAFCDSB19

Net Price Each\*: \$0.45

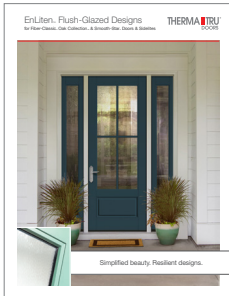

**Updated EnLiten™ Flush-Glazed Designs Brochure**

Show the advantages of Therma-Tru's flush-glazed doors to create a clean look with a wider daylight opening.

MAFFGB19

Net Price Each\*: \$0.40



**NEW Elevate 2019 Brochure**

Introduce the 2019 product campaign, Elevate, which showcases new products targeted to connect with homeowners on a personal level, inspired by in-depth research.

MAFNP19

Net Price Each\*: \$1.05



**Updated 7'0" Door & Sidelite Solutions Brochure**

Find 7'0" products to help you make the most of trends toward higher ceilings in new homes and to replace existing openings.

MAFSFB19

Net Price Each\*: \$0.45



**Updated Door Collection Sheets**

Provide an overview of each of Therma-Tru's door collections and make great additions to homeowner care and maintenance packets or to be used as showroom handouts. Can be purchased individually or as a set.

**Starter Kit**

Includes 25 sheets of each of the Therma-Tru door collections – Classic-Craft, Fiber-Classic, Smooth-Star and Pulse.

MACLCTNSK19

Net Price Each\*: \$12.00



**Door Collection Sheets (Individual)**

**CCA Sheets**  
MACCACLCTN19

**CCM Sheets**  
MACCMCLCTN19

**CCR Sheets**  
MACCRCLCTN19

**CCO Sheets**  
MACCOCLCTN19

**CCV Sheets**  
MACCVCLCTN19

Net Price Each\*: \$1.25

**FCM Sheets**  
MAFCMCLCTN19

**FCO Sheets**  
MAFCOCLCTN19

**SS Sheets**  
MASSCLCTN19

**Pulse Sheets**  
MAPLSCLCTN19

\*\*Therma-Tru Shopper Journey Study, 2016; n = 751



### Experience the Difference – Sales Pitchbook

Empower your sales team to close more effectively by knowledgeably discussing the benefits of Therma-Tru premium products. Spiral bound and fits in a pocket.

MASPP18

Net Price Each\*: \$5.50



### Therma-Tru. Folder

A great way to bundle Therma-Tru literature. It even has a place for your business card!

MAFF10

Net Price Each\*: \$0.70



### Same-Day. Stain Finishing Instructions

MAFSI13

Net Price Each\*: \$0.25

### Model Home Program

View and download Therma-Tru Model Home Program information and claim form on the Customer Portal.

## TRAINING AIDS AND DOCUMENTS

# Installation and Training

These tools have everything you need to make the installation and maintenance of any Therma-Tru products straightforward and successful.

### Bilingual Installation Instructions

Entry and Patio Doors (English and Spanish)

MSDRIST65

Net Price Each\*: No Charge

### Bilingual Installation Instructions

Entry and Patio Doors with Vented Sidelites (English and Spanish)

MSDRIST-VS

Net Price Each\*: No Charge

To download installation instructions, please visit [thermatru.com/customer-support/how-to-center/how-to-install-your-door](http://thermatru.com/customer-support/how-to-center/how-to-install-your-door).

## Unit Dimension Tape Measures

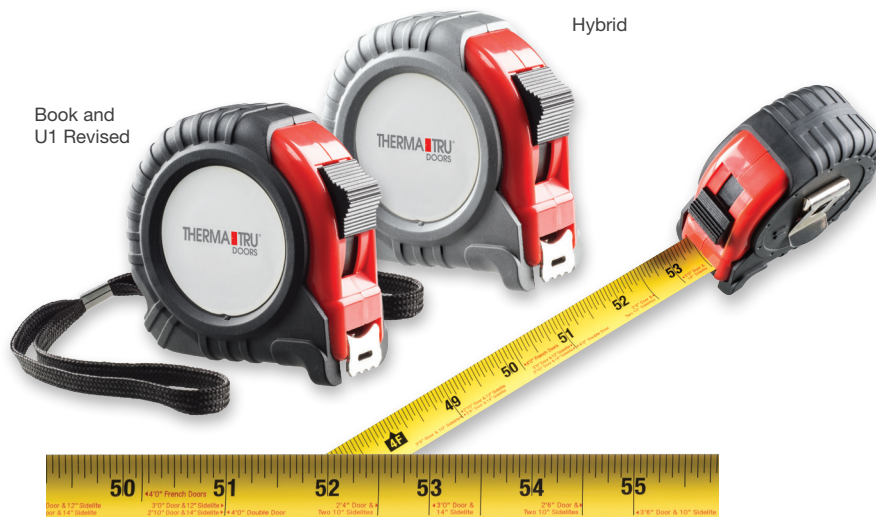

Book and U1 Revised

Hybrid

Take the guesswork out of measuring openings from 2'0" single doors to 9'0" triple doors – and everything in between. This tape measure features unit dimension widths and heights to help simplify the door measuring process.

Book Size: MADUDTPMSRBK16

U1 Revised Size: MADUDTPMSRU1R16

Hybrid Size: MADUDTPMSRHY16

Net Price Each\*: \$5.50

# Custom Marketing Program

Create marketing pieces tailored to your business through our Custom Marketing Program. Brochures, yard signs, door hangers, direct mail postcards and mail stuffers are available to customize with your own message – helping you differentiate your business and reach potential customers in your market.

## Templates



Horizontal Catalog

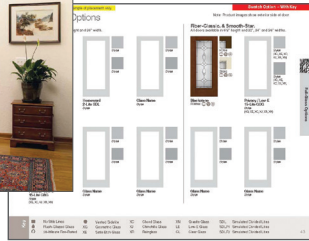

Vertical Catalog



8 Page Brochure



6 Page Brochure

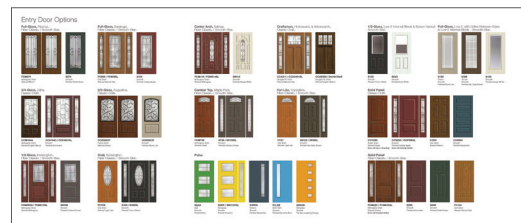

### Feature Products By:

- Glass Shape
- Glass Design

### Custom Literature

Custom literature is an industry-proven tool that showcases your business and the Therma-Tru<sup>®</sup> products you sell.

- Choose from a variety of customizable templates.
- Select products for your business.
- Create messaging designed to tell the story of your business.
- Show what a difference a stylish new Therma-Tru door makes and help bring out the best of the home's style with the Curb Appeal and Architectural Home Styles Guide template pages.

PrismaGuard<sup>™</sup> Brochure

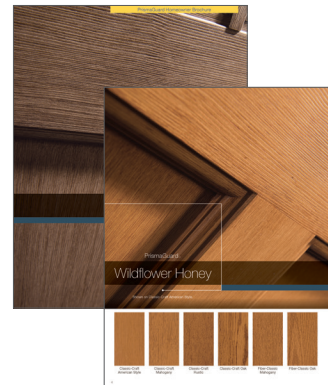

### Yard Sign



### Door Hanger

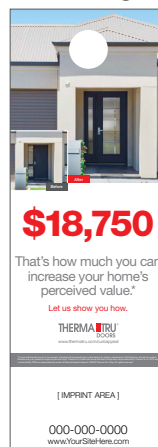

### Postcard



### Mail Stuffer



### Yard Signs, Door Hangers, Postcards & Mail Stuffers

Target customers with your message.

- Increase visibility and referrals with a customized yard sign for your job sites.
- Communicate your brand door-to-door with door hangers.
- Customize a direct mail program with postcards and mail stuffers.

# Sell Sheet & Door Signage Templates

Create professional PowerPoint sell sheets and display door signage supporting your business with your company information – it's quick and easy. Visit [thermatru.com/builder](http://thermatru.com/builder) for details.

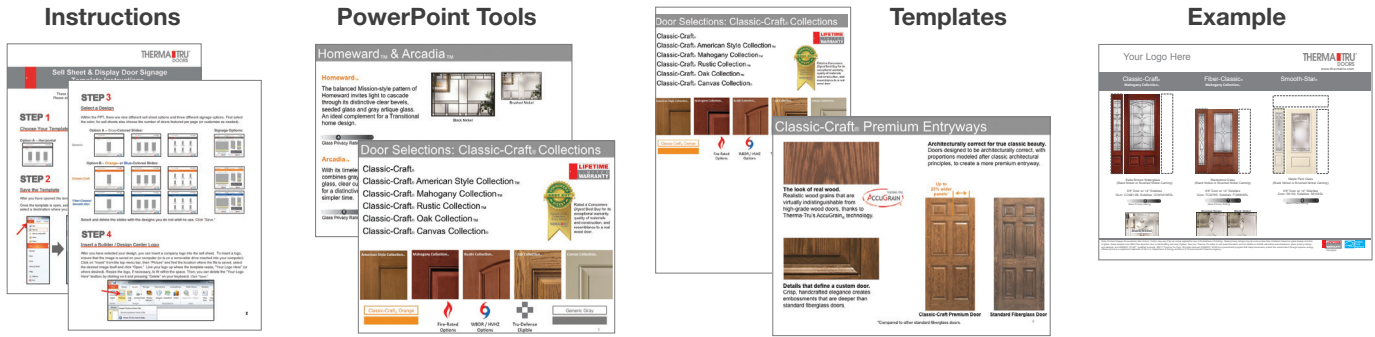

## Door Signage Templates

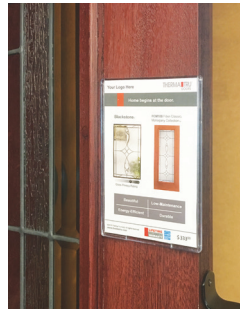
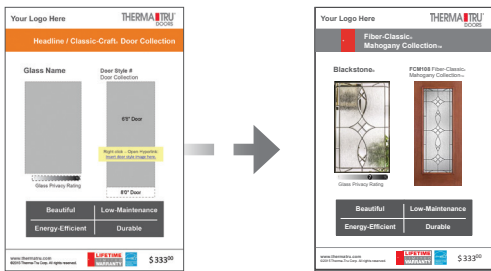

## 4" x 6" Door Signage Holder

Showcase your custom designed 4" w x 6" h display door signage with this sign holder. Add on one or both sides of the display door. Each sign holder comes with two strips of double-sided tape.

MAD4X6SIGNHLDR  
Net Price Each\*: \$3.00

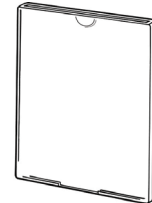

## Updated Technical Documents

### Technical Manuals

These documents are also available for you to download at [thermatru.com](http://thermatru.com).

### Door Styles Manual

Book: MAEDSTYLE19BOOK  
U1 Revised: MAEDSTYLE19U1REV  
Hybrid: MAEDSTYLE19U4  
Net Price Each\*: \$40.00

### Architectural Details & Components

Book: MAEDCOMP19BOOK  
U1 Revised: MAEDCOMP19U1REV  
Hybrid: MAEDCOMP19U4  
Net Price Each\*: \$32.00

### Site Manual

MAED19SITE  
Net Price Each\*: \$15.00

### Shop Manual

Book: MAEDSHOP19BOOK  
U1 Revised: MAEDSHOP19U1REV  
Hybrid: MAEDSHOP19U4  
Net Price Each\*: \$38.50

### Unit Rough Opening Sizing Booklet

Book: MAEDCOMPDD19BOOK  
U1 Revised: MAEDCOMPDD19U1REV  
Hybrid: MAEDCOMPDD19U4  
Net Price Each\*: \$1.50

### Warranty Documents

Provide your customers with warranty documents that will help them appreciate how Therma-Tru will stand behind their purchase. These documents are available for you to download at [thermatru.com](http://thermatru.com) or on our Digital Vault.

- **Fiberglass & Steel Entry & Patio Door System Warranty**
- **Tru-Defense® Fiberglass Door Systems Rider**
- **Same-Day® Stain Warranty**
- **EnLiten™ Flush-Glazed Rider for Construction & Installation**
- **EnLiten™ Flush-Glazed Rider for Homeowners**
- **PrismaGuard™ Warranty**



\*Pricing subject to change without notice.  
\*\*Traqline, 2015; n= 3,102



# Company Store

To see all the Therma-Tru. branded wearables and leave-behinds, visit the company store at [tiggear.com/thermatrugear](http://tiggear.com/thermatrugear). Large quantity quotes available upon request. Minimum order quantities may apply.

Watch for new offerings in the full company store at [tiggear.com/thermatrugear](http://tiggear.com/thermatrugear)

Company Store



**Summit Full Zip Fleece Vest**

100% polyester microfleece vest.  
Net Price Each\*: \$28.60



**Light Softshell Jacket**

100% polyester softshell waterproof jacket with zippered pockets and elastic cuffs.  
Net Price Each\*: \$57.50



**Polo Shirt**

Classic black polo shirt with Therma-Tru logo embroidered on left chest. Also available in khaki and navy for special order. Limited sizes available.  
Net Price Each\*: \$20.50



**T-Shirt**

100% cotton gray T-shirt.  
Net Price Each\*: \$5.75



**Captain's Chair**

Folding chair with two mesh can holders in arm rests. Comes with a polyester drawstring carrying bag.  
Net Price Each\*: \$21.50



**Drawstring Backpack**

Drawstring bag with additional front pocket and mesh bottle holder.  
Net Price Each\*: \$8.40



**Tablet Case**

Sleeve with waffle-style interior, stand bar and stylus port offers stylish and functional protection.  
11-1/2"h x 7-3/4"w x 3/4"d  
Net Price Each\*: \$20.00



**Black 6-Pack Insulated Cooler Bag**

Foam-insulated and water-resistant PEVA lining. Double zipper closure with Therma-Tru logo in white.  
Net Price Each\*: \$4.00



**Carpenter Pencil**

Traditional red carpenter pencil.  
Net Price Each\*: \$0.38



**Pro Locking Tape Measure**

25' retractable metal tape (standard and metric) with lock button, wrist strap and metal belt clip.  
Net Price Each\*: \$5.00



**Black Cap**

100% flat cotton twill.  
Net Price Each\*: \$5.00



**Stainless Steel Tumbler**

Foam-insulated, double-wall tumbler with twist-on plastic lid.  
Net Price Each\*: \$4.95



**Double Trouble Pen Highlighter**

Twist-action ballpoint pen and highlighter with removable cap.  
Net Price Each\*: \$0.75



**Red Door Stress Reliever**

Net Price Each\*: \$1.55



**Adhesive 3" x 3" Notepad**

25 Sheets  
Net Price Each\*: \$0.30



**Collapsible Can Coozie**

Holds and insulates 12 oz. cans.  
Net Price Each\*: \$0.65

# ThermaTru.com

## Design Your Door

Make it easier to shop for entry doors. Homeowners can research and design a door with their own personal touch – all from the convenience of home – then email you for an estimate.

[thermatru.com/explore-doors/design-your-door](http://thermatru.com/explore-doors/design-your-door)

Talk to your Therma-Tru Sales Representative about how you can add this configurator to your website.

**Dealer** – [thermatru.com/dealer](http://thermatru.com/dealer)

**Builder/Remodeler** – [thermatru.com/builder](http://thermatru.com/builder)

**Contractor** – [thermatru.com/contractor](http://thermatru.com/contractor)

**Architect** – [thermatru.com/architect](http://thermatru.com/architect)

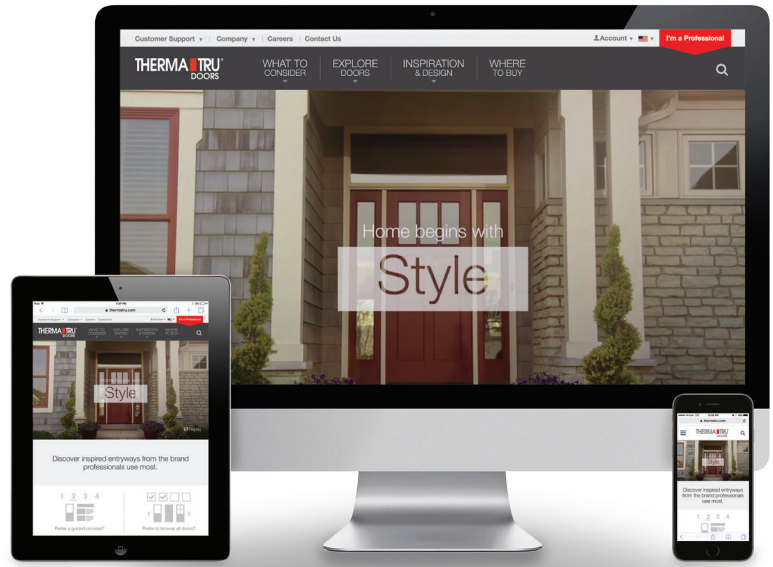

## Inspiration Gallery

Homeowners and building professionals can upload photos to Instagram or Twitter using the hashtag #ThermaTru for a chance to be featured in our online Inspiration Gallery.

## Therma-Tru's Digital Vault

Explore our Digital Vault to find advertising elements, promotional literature, images, logos and other branding assets. This is your source for the materials and tools you use most when promoting the Therma-Tru products you offer.

Create an account today at [thermatru.widencollective.com/login](http://thermatru.widencollective.com/login).

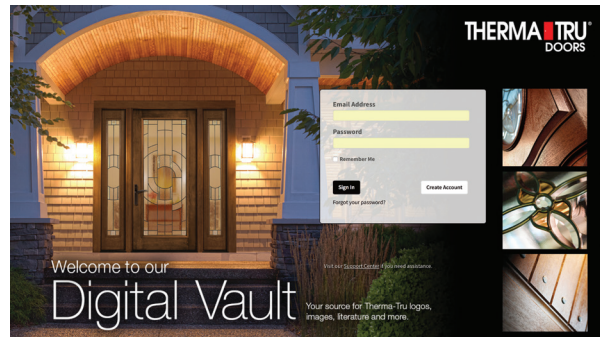

## Ad Planner

Utilize our Ad Planner to access Therma-Tru ads that you can use to promote your business in digital and print publications. You will also find on-hold messaging scripts, truck graphics and more.



## Updated Architectural Home Styles Guide

The power of curb appeal captures attention. And it starts with a stylish front entry door from Therma-Tru. Get inspired to choose entry doors by design with our interactive guide to popular home styles.

[homestyles.thermatru.com](http://homestyles.thermatru.com)

## Dealer Microsite Landing Pages



Increase your local online visibility with a Therma-Tru® dealer microsite landing page. This co-branded site connects our website with yours and can help more qualified leads find you online. Ask your Therma-Tru Sales Representative for details.

## EasySpec™ Drawing Tools

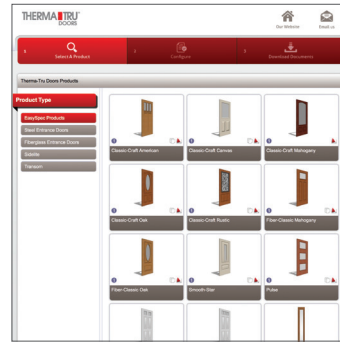

Everything architects and dealers need to specify Therma-Tru doors in one place, including 2D CAD drawings available in multiple file types and product information with 3-part specification documents.

[thermatru.com/architect](http://thermatru.com/architect)

## Unlock the Opportunities



Learn about our new products and door system solutions, and enter for a chance to win prizes.



[unlocktheopportunities.com](http://unlocktheopportunities.com)

## Education Center

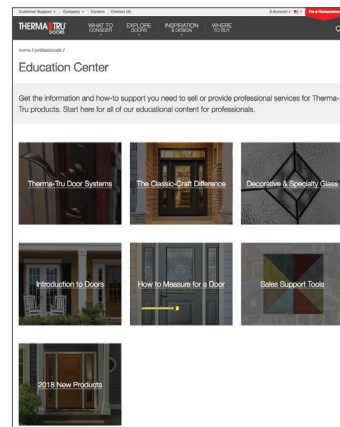

Learn from the experts in fiberglass doors and test your door IQ on a variety of topics.

[thermatru.com/learning](http://thermatru.com/learning)



\*Source: Therma-Tru Shopper Journey Study, 2016; n = 751



Download our DoorWays™ App and visualize the perfect entry for any home and style.



thermatru.com  
1-800-THERMA-TRU (843-7628)  
1750 Indian Wood Circle  
Maumee, OH 43537



Please visit our Digital Vault for a digital copy of this brochure.  
[thermatru.widencollective.com/login](https://thermatru.widencollective.com/login)